

RKR 3000 Manually operated hydraulic tool for inserts from M3 to M12

new

Code 510312

Operating System

The manually operated hydraulic tool RKR 3000 is designed to place blind rivet nuts from M3 to M12 and blind rivet studs from M4 to M8.

Due to its high setting force, the RKR 3000 is also able to place high-strength blind rivet nuts. The tool's maximum setting force is 25 000 N, however it is possible to steplessly adjust the setting force from 1 000 N to 25 000 N.

A pressure relief valve guarantees that the tool stops when reaching the adjusted setting force. The tool's stroke is 9 mm (.38").

The all-new RKR 3000 is simple to operate and easily handled.

It is possible to place blind rivet nuts and blind rivet studs with a left-handed thread.

On request, a nosepiece extended by 90 mm (3.8") is available.

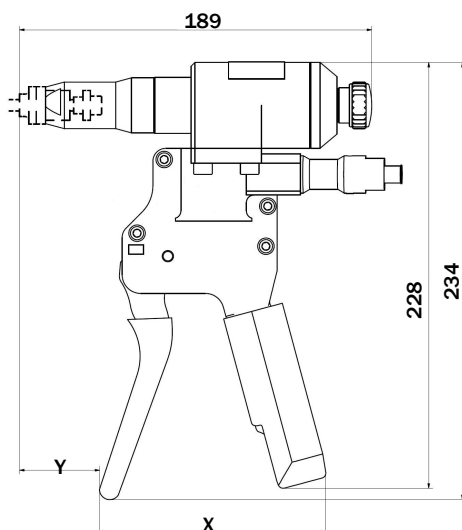
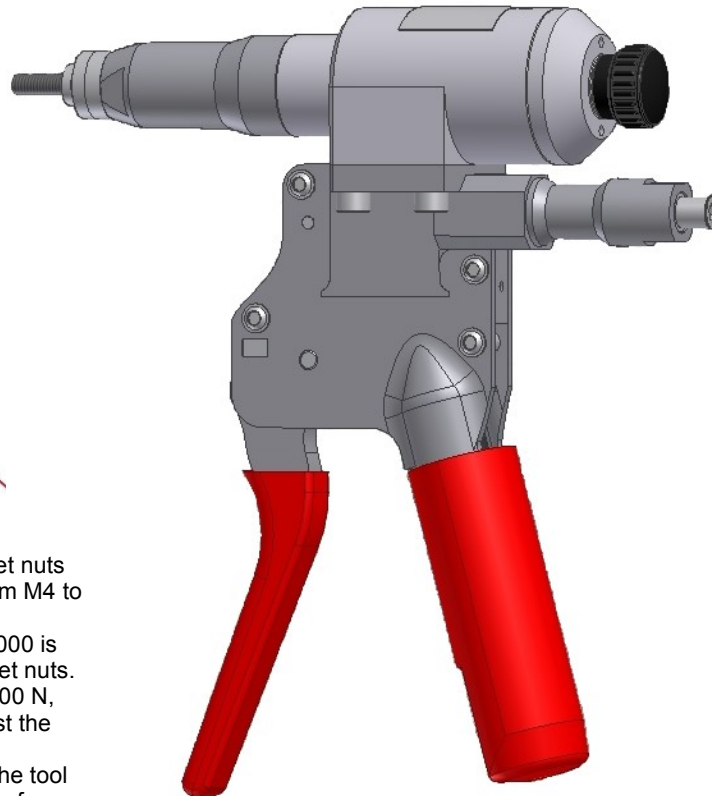

Working position: X= 121 mm Y= 43 mm
Release position: X= 138 mm Y= 26 mm

Extended nosepiece:



Technical data and features

Stroke	9 mm (.38")
Maximum setting force	25 000 N
Weight	1.7 kg (3.75 lbs)
Dimensional range:	
Blind rivet nuts	M3 to M12
Blind rivet studs	M4 to M8

Richard Kreuzer Montagesysteme Werkzeugtechnik GmbH

Am Mailinger Moos 8 – 85055 Ingolstadt

Telefon: +49 (0) 841/93 15 18 66

Fax: +49 (0) 841/93 15 18 68

E-Mail: info@kreuzer-online.com

www.kreuzer-online.com